

AIRCRAFT WARNING LIGHTS

MEDIUM INTENSITY OBSTRUCTION LIGHT MIOL - B / MIOL - C



AWL - MIOL - B/C



AIRCRAFT WARNING LIGHTS

MIOL - B / MIOL - C

KEY FEATURES

- Based on LED technology
- 2.000 cd night mode, RED flashing for MIOL-B
- 2.000 cd night mode, RED steady burning for MIOL-C
- Long life time >10+ years life expectancy
- Low consumption
- Stabilised light output
- Lightweight and compact
- Low wind load factor
- Alarm/remote status control
- Easy to install
- No RF-radiations
- Light output alignment device
- Patented beacon (EU 001929910-0001; Canada 145 189; USA D673,474)

OPTICAL FEATURES

- Cd emission @ -0,5° and +4°
- Horizontal beam radiation 360°
- Vertical beam spread 4°
- PMMA lens

OPTIONS

- Twin version: two galvanically separated circuits in the same fixture
- Wind Collector
- Beacon support bracket
- Power supply AC or DC
- GPS (Global Position System) syncro
- Infrared available

ELECTRICAL FEATURES

- Average power consumption for MIOL-B (@20fpm): 9W
- Average power consumption for MIOL-B (@40fpm): 12W
- Average power consumption for MIOL-B (@60fpm): 15W
- Average power consumption for MIOL-C (steady burning) : 54W
- LED feeded at constant current
- Lightning protection

MECHANICAL FEATURES

- Anodised aluminium body with heat-sink for natural draft air cooling
- RAL7035 painted aluminium body lamp
- Bottom wind collector for central heat-sink cooling
- Borosilicate glass cover protection
- Silicon gasket
- Degree of protection: IP66
- Operating temperature: -50°C to +80°C
- Storage temp. range: -20°C to +45°C
- Lamp unit weight: 6kg

APPLY TO

- Airport - Stack - High building - Chimney - Tower crane
- Pipe line - Bridge - Radio and television tower
- Transmission line - Wind turbine - Wind mast measurement
- Radar - Antenna

INTERNATIONAL REGULATION

- ICAO Aerodromes -Annex 14 Volume 1, 6th Edition, July 2013 Chapter 6: Medium intensity, Type B flashing obstacle light MIOL-B type or Type C steady burning obstacle light MIOL-C type
- FAA AC150/5345-43F E.B. #67 Lamp type L-864 or Twin L-864
- DGAC/STAC approval nr. 2013A037
- ENAC approval nr. 0135182/ENAC/CIA
- CE marking

AIRCRAFT WARNING LIGHTS

MIOL - B / MIOL - C

Order code

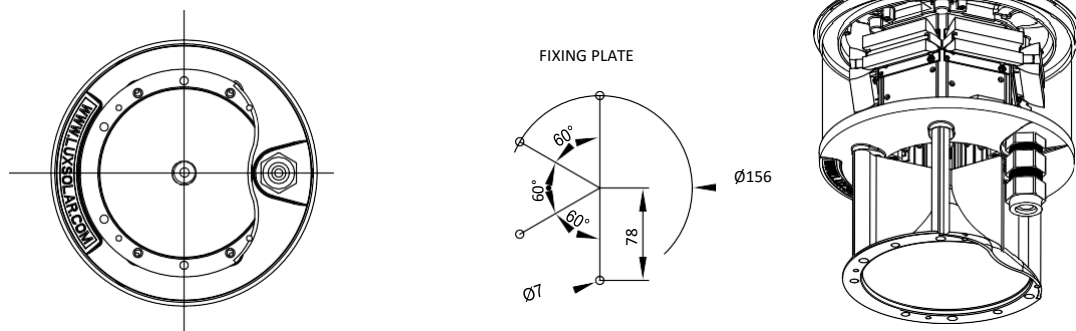
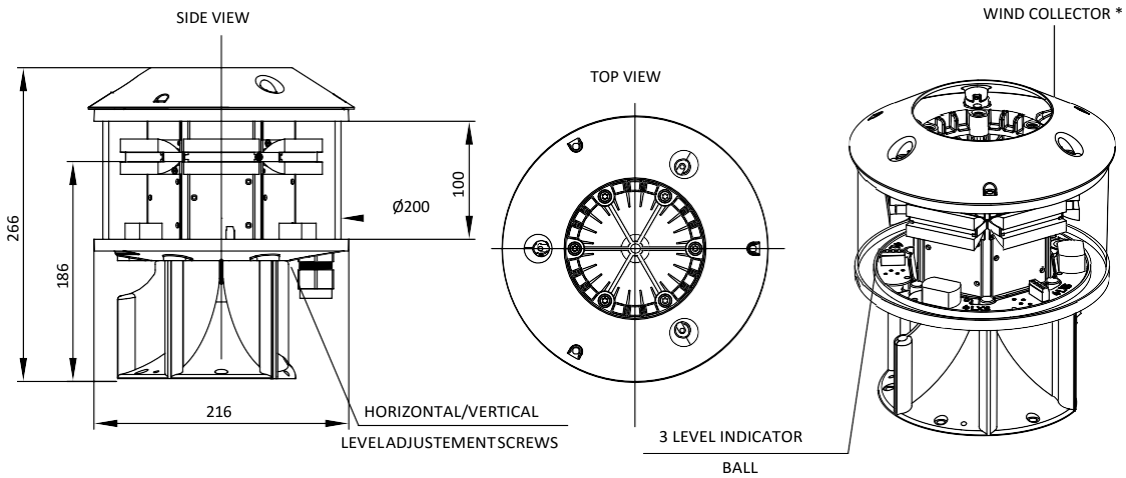
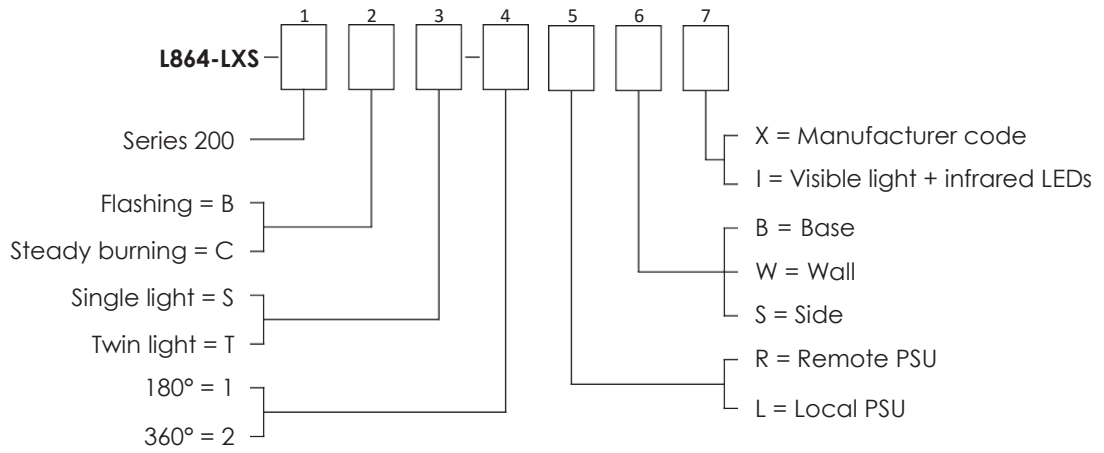

AIRCRAFT WARNING LIGHTS

MIOL - B / MIOL - C

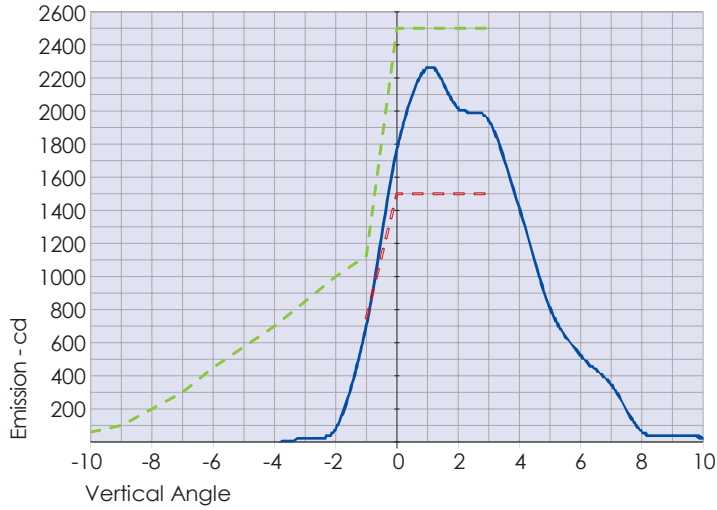

- L864-LXS-B average emission level at 90°C ambient temperature
- - - ICAO ANNEX 14 medium intensity type B/C Minimum Required Intensity
- - - ICAO ANNEX 14 medium intensity type B/C Maximum Required Intensity

AWL - MIOL - B/C

CERTIFICATIONS



FEATURES

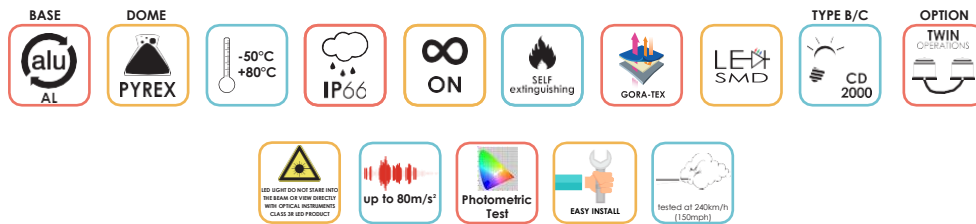

TYPICAL APPLICATION

